

Indexing

Introduction to Databases

CompSci 316 Fall 2017



DUKE
COMPUTER SCIENCE

Announcements (Thu., Nov. 9)

- Project milestone #2 due today
- Homework #3 sample solution to be posted on Sakai by this weekend
- Homework #4 to be assigned next Tuesday

What are indexes for?

- Given a value, locate the record(s) with this value

```
SELECT * FROM R WHERE A = value;
```

```
SELECT * FROM R, S WHERE R.A = S.B;
```

- Find data by other search criteria, e.g.

- Range search

```
SELECT * FROM R WHERE A > value;
```

- Keyword search

} Focus
of this
lecture

database indexing

Search

Dense and sparse indexes

- **Dense**: one index entry for each search key value
 - One entry may “point” to multiple records (e.g., two users named Jessica)
- **Sparse**: one index entry for each block
 - Records must be **clustered** according to the search key

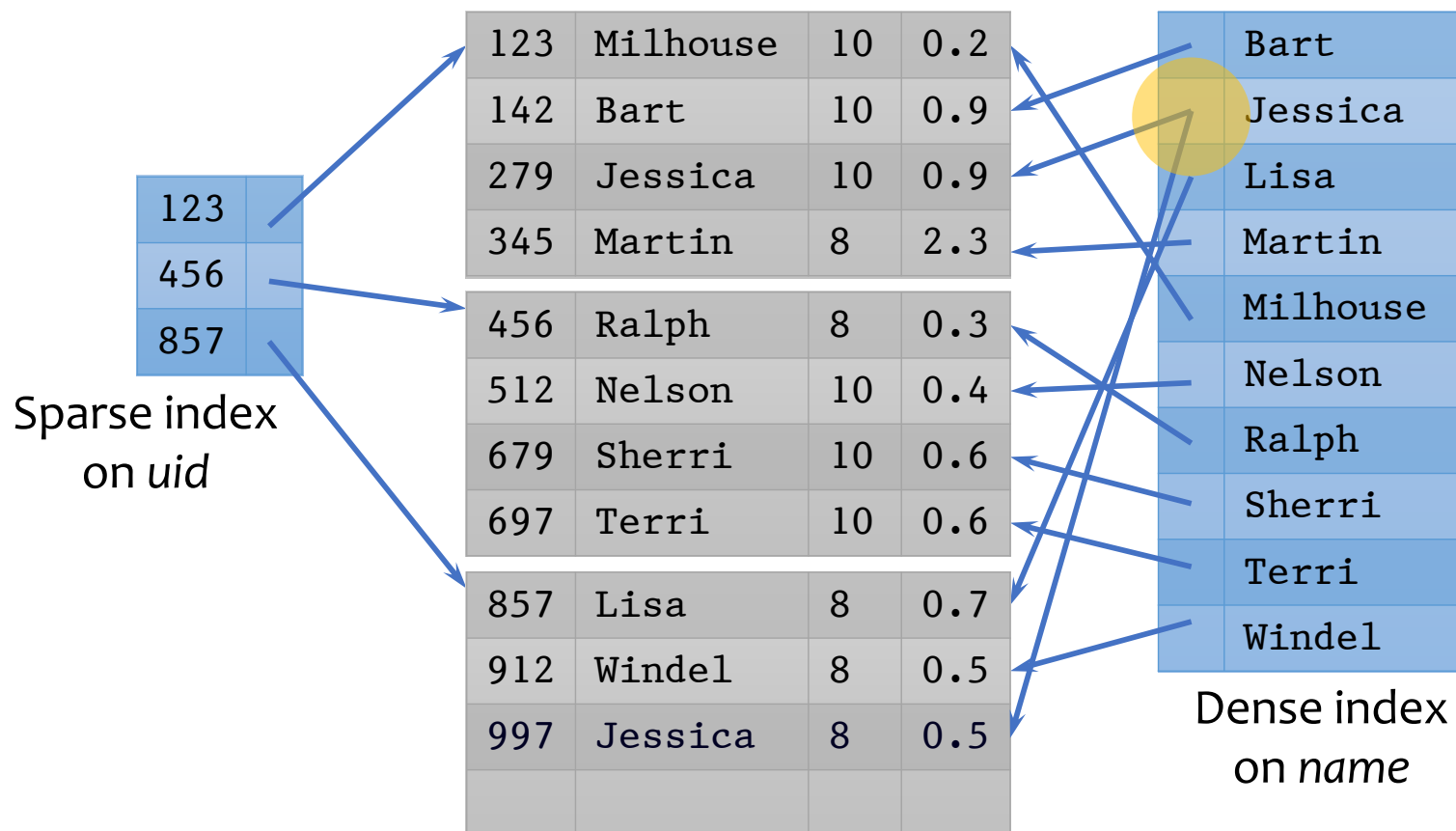

Dense versus sparse indexes

- Index size
 - Sparse index is smaller
- Requirement on records
 - Records must be clustered for sparse index
- Lookup
 - Sparse index is smaller and may fit in memory
 - Dense index can directly tell if a record exists
- Update
 - Easier for sparse index

Primary and secondary indexes

- **Primary index**

- Created for the **primary key** of a table
- Records are usually clustered by the primary key
- Can be sparse

- **Secondary index**

- Usually dense

- **SQL**

- PRIMARY KEY declaration automatically creates a primary index, UNIQUE key automatically creates a secondary index
- Additional secondary index can be created on non-key attribute(s):

```
CREATE INDEX UserPopIndex ON User(pop);
```

ISAM

- What if an index is still too big?
 - Put a another (sparse) index on top of that!
 - ☞ **ISAM (Index Sequential Access Method)**, more or less

Example: look up 197

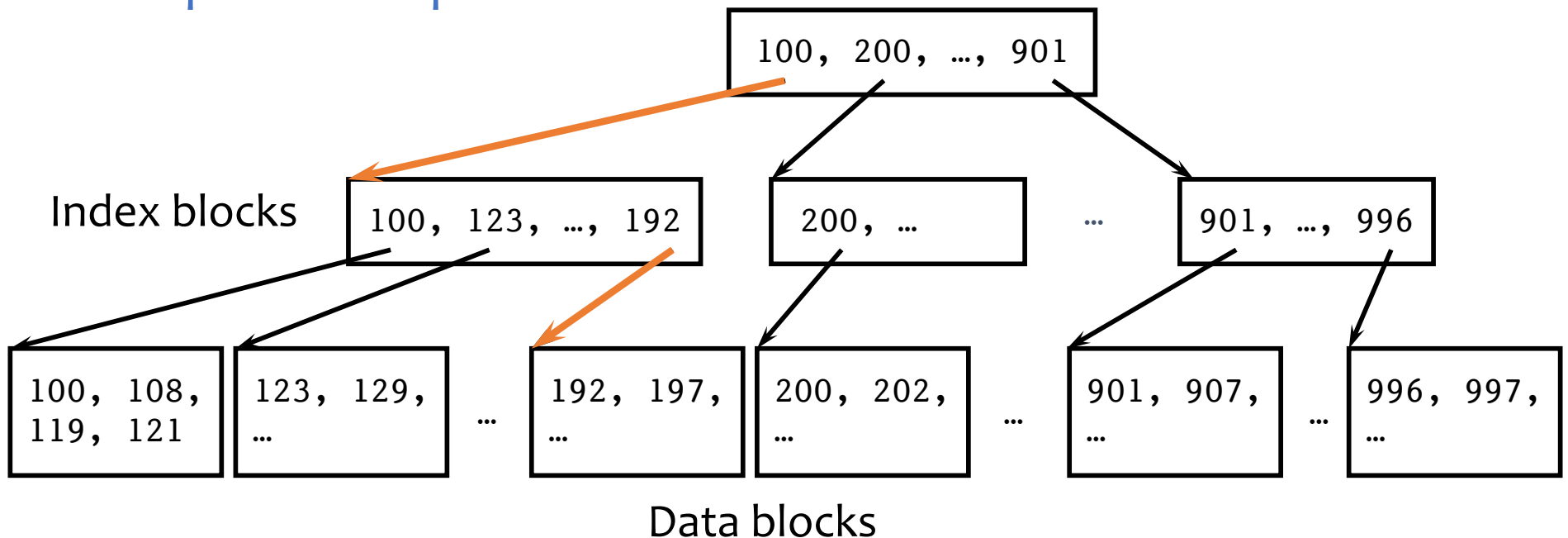

Updates with ISAM

Example: insert 107

Example: delete 129

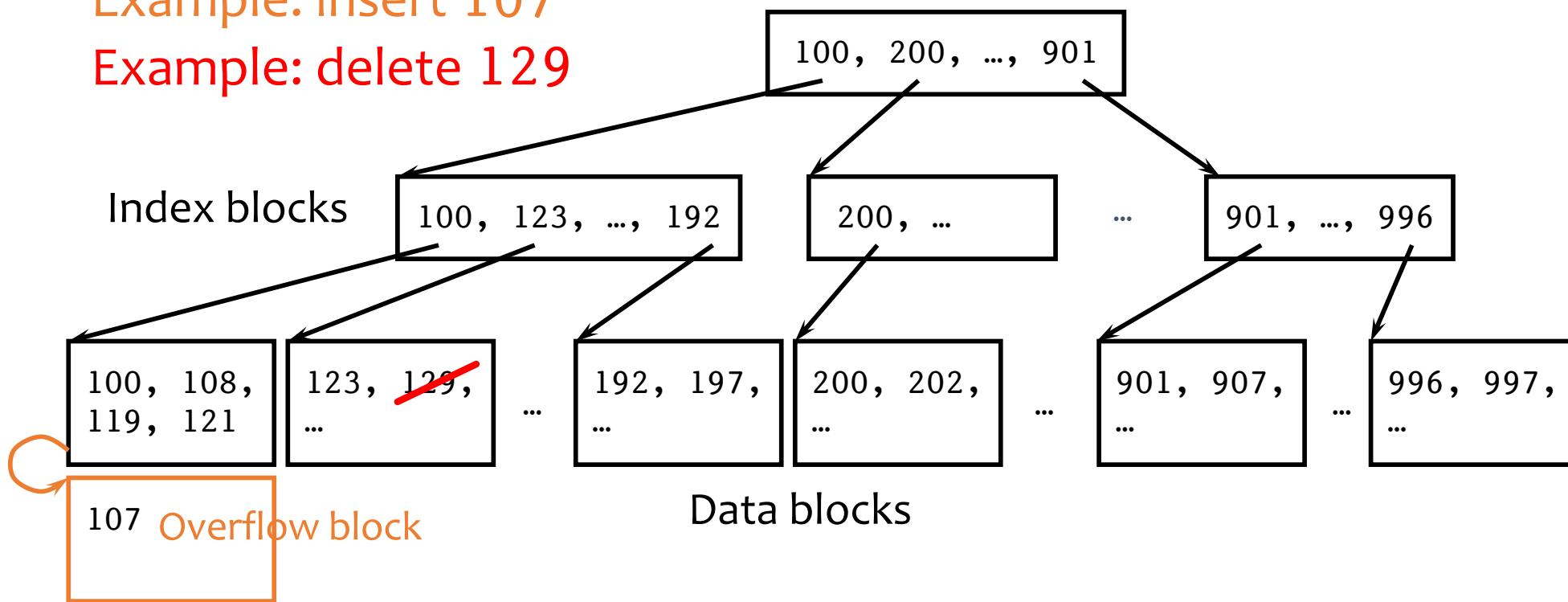

-

- Worst case:

B⁺-tree

- A **hierarchy of nodes with intervals**
- **Balanced** (more or less): good performance guarantee
- **Disk-based**: one node per block; large fan-out

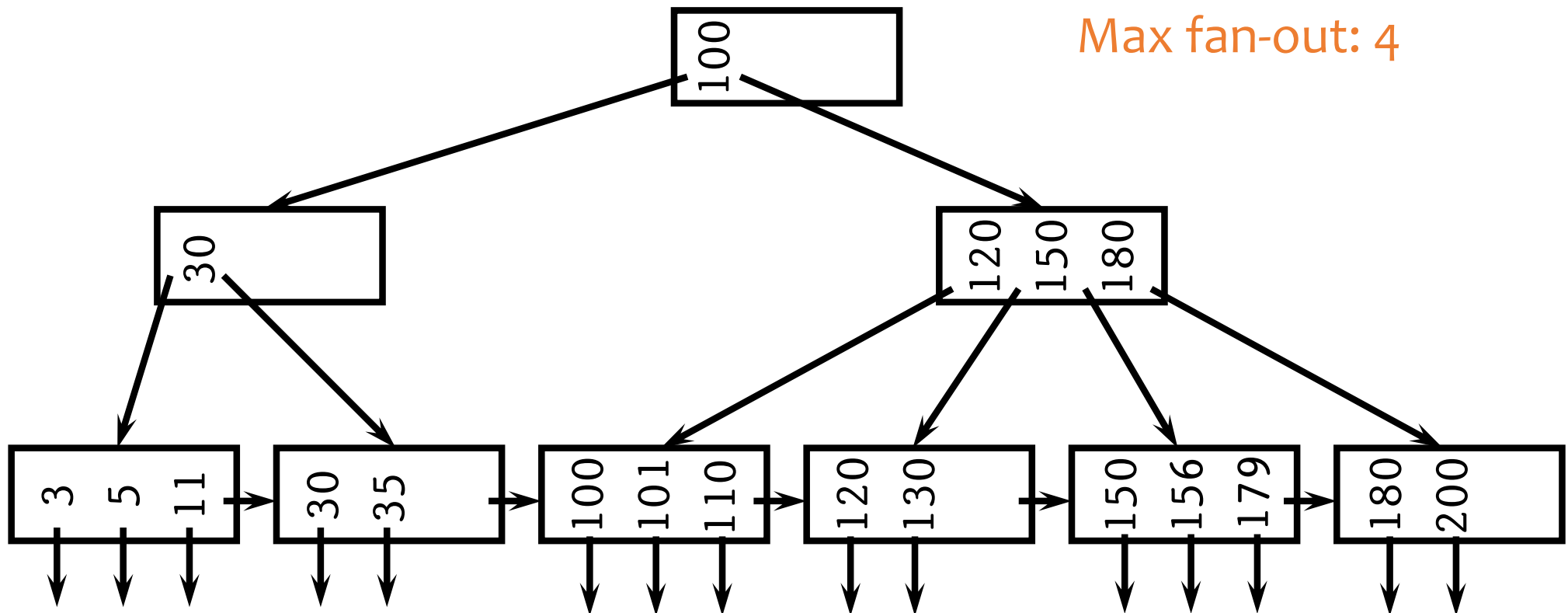

Sample B⁺-tree nodes

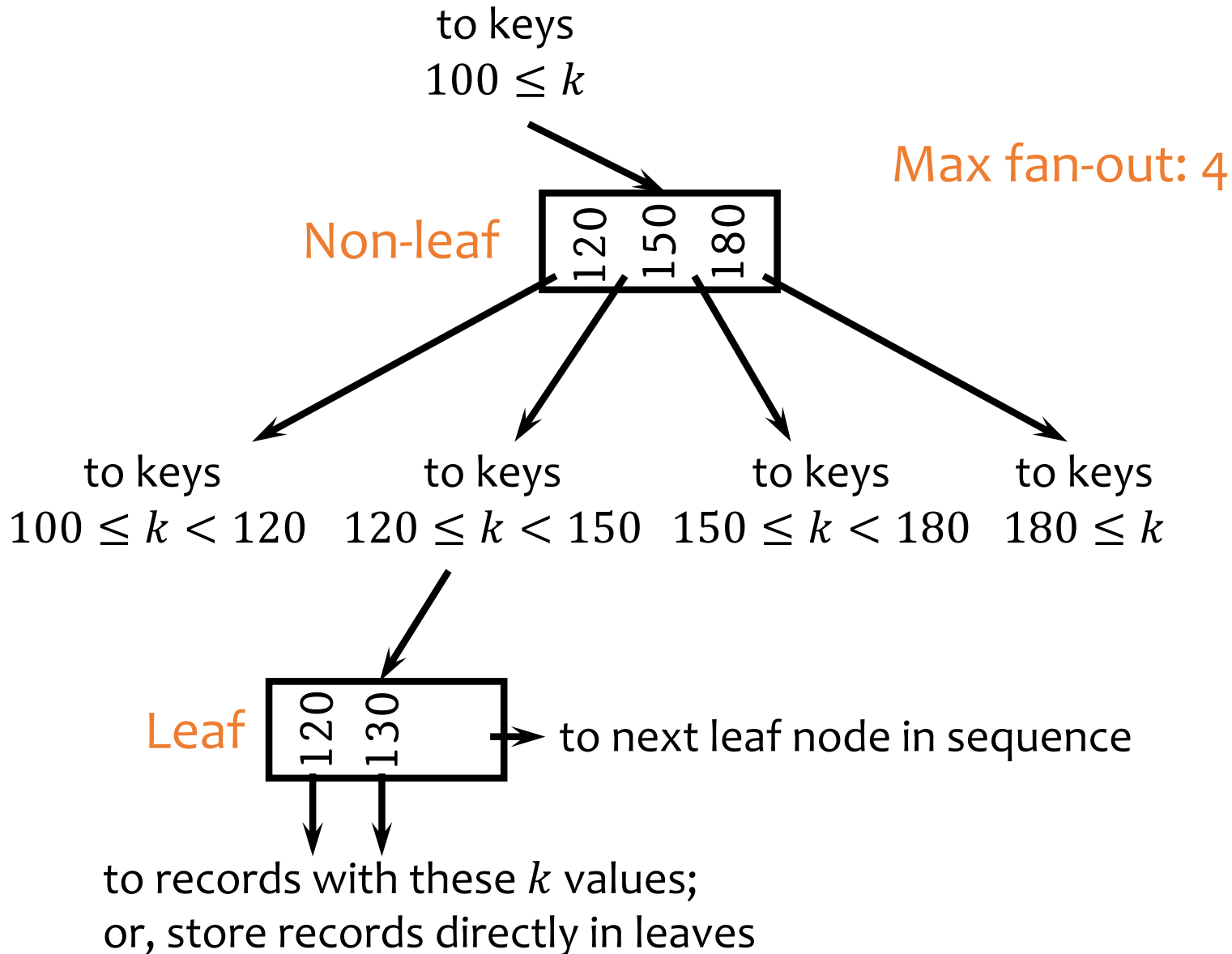

B⁺-tree balancing properties

- Height constraint: all leaves at the same lowest level
- Fan-out constraint: all nodes at least half full (except root)

	Max # pointers	Max # keys	Min # active pointers	Min # keys
Non-leaf	f	$f - 1$	$\lceil f/2 \rceil$	$\lceil f/2 \rceil - 1$
Root	f	$f - 1$	2	1
Leaf	f	$f - 1$	$\lceil f/2 \rceil$	$\lceil f/2 \rceil$

Lookups

- SELECT * FROM R WHERE $k = 179$;
- SELECT * FROM R WHERE $k = 32$;

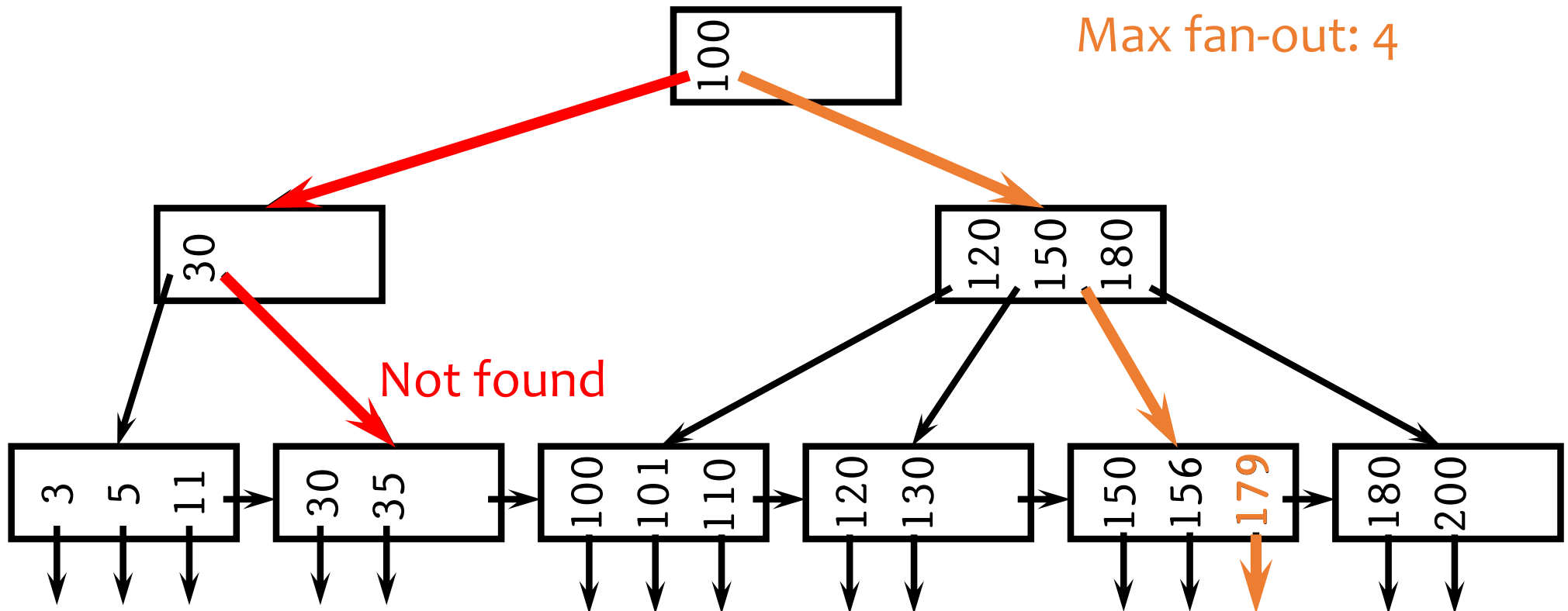

Range query

• SELECT * FROM R WHERE $k > 32$ AND $k < 179$;

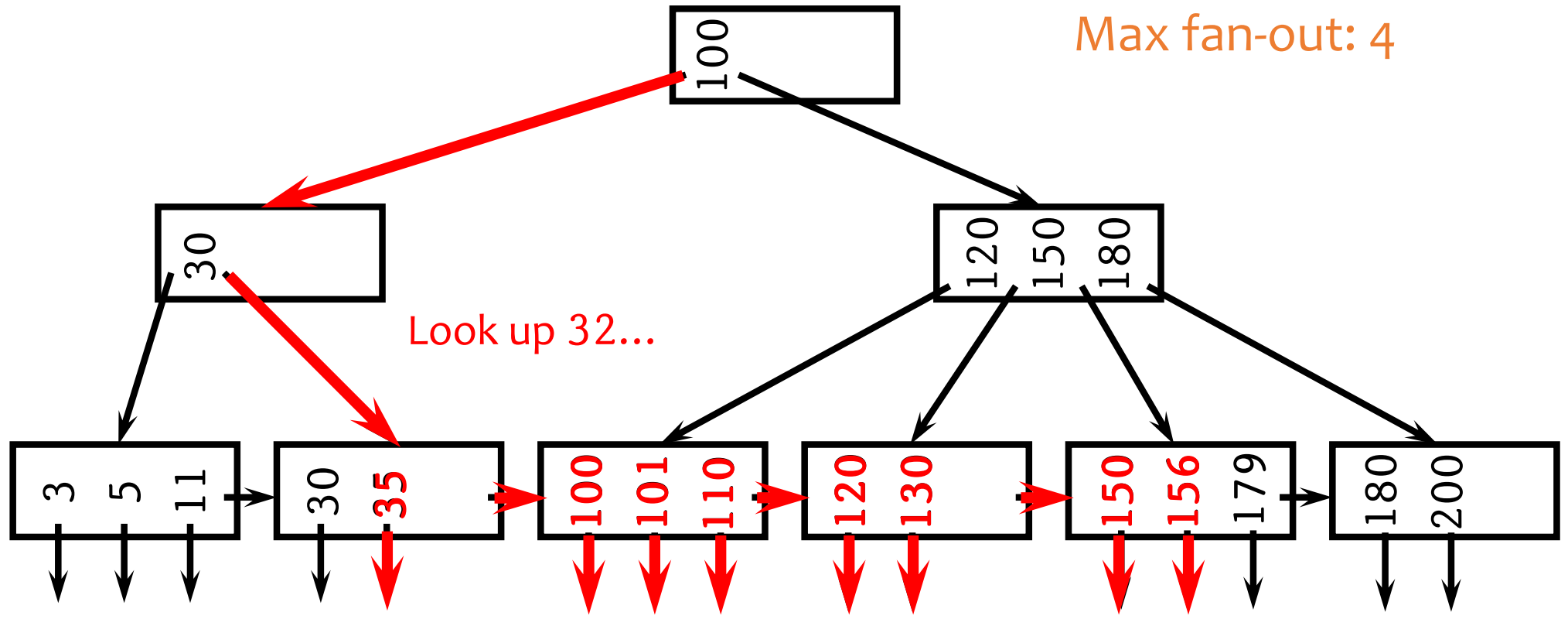

And follow next-leaf pointers until you hit upper bound

Insertion

- Insert a record with search key value 32

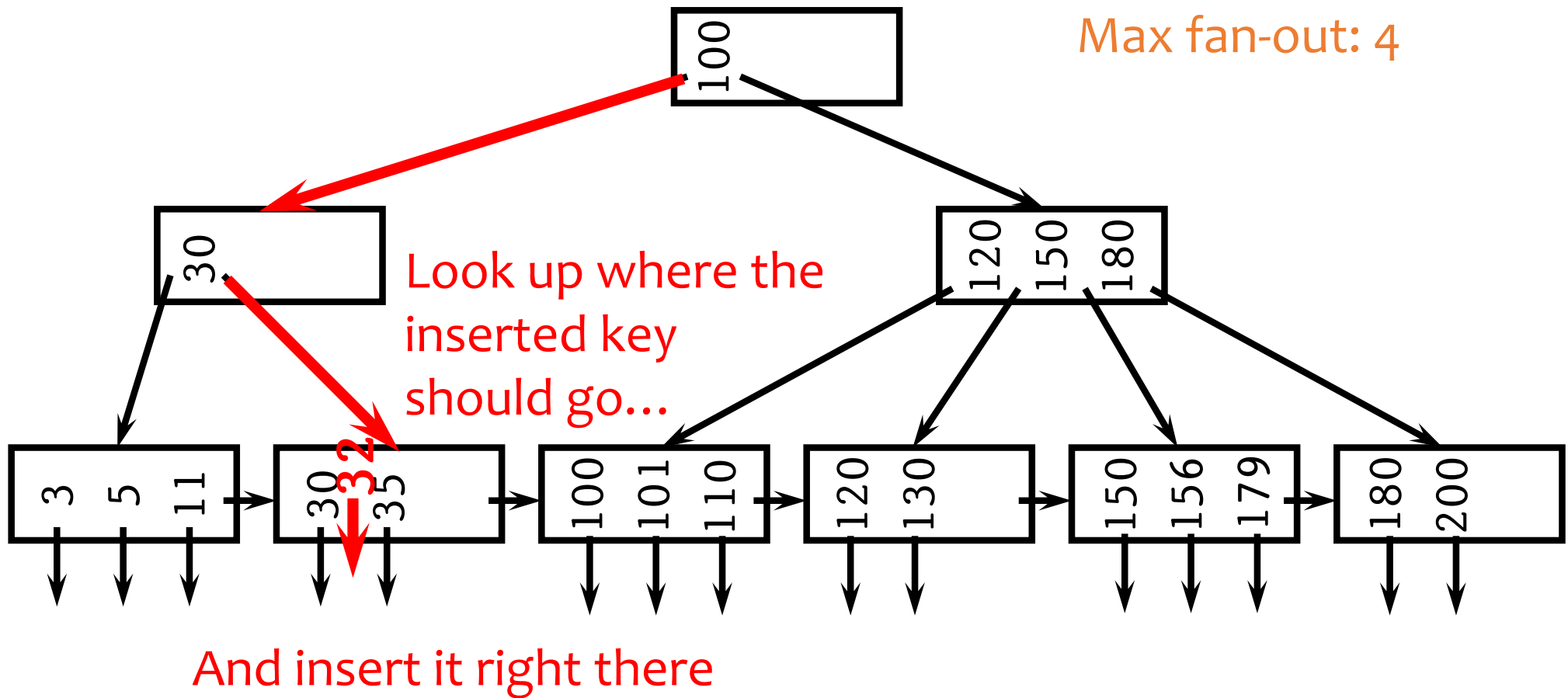

Another insertion example

- Insert a record with search key value 152

Max fan-out: 4

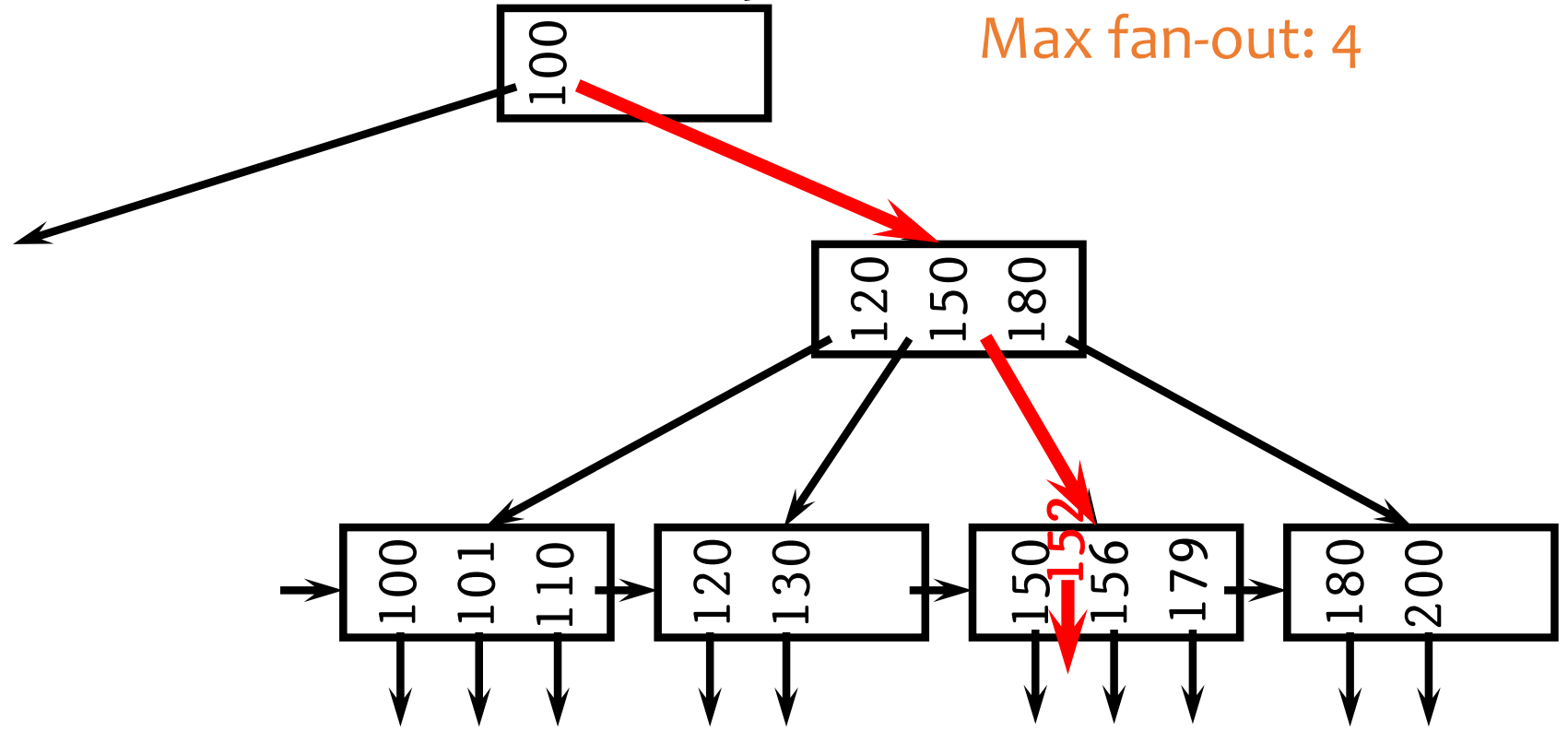

Oops, node is already full!

Node splitting

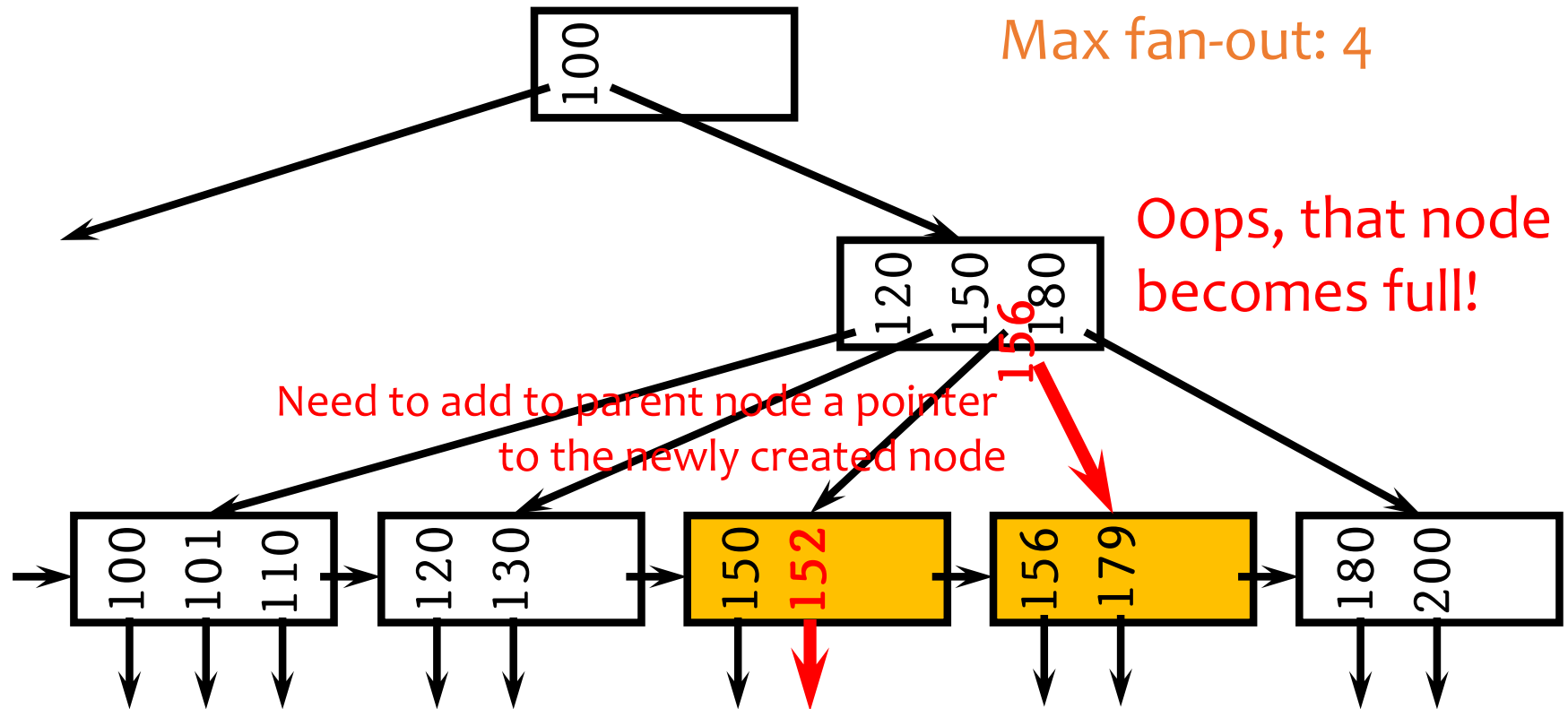

More node splitting

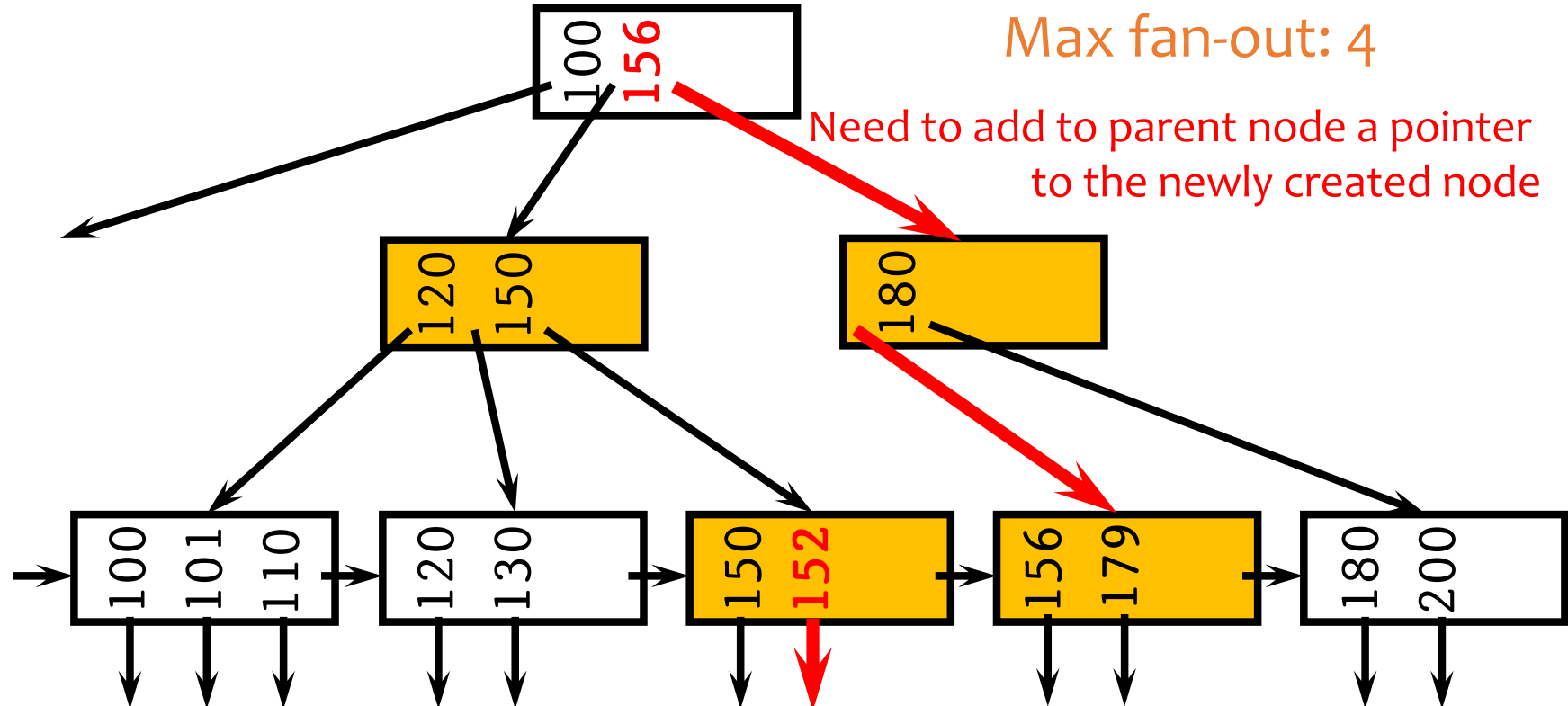

- In the worst case, node splitting can “propagate” all the way up to the root of the tree (not illustrated here)
 - Splitting the root introduces a new root of fan-out 2 and causes the tree to grow “up” by one level

Deletion

- Delete a record with search key value 130

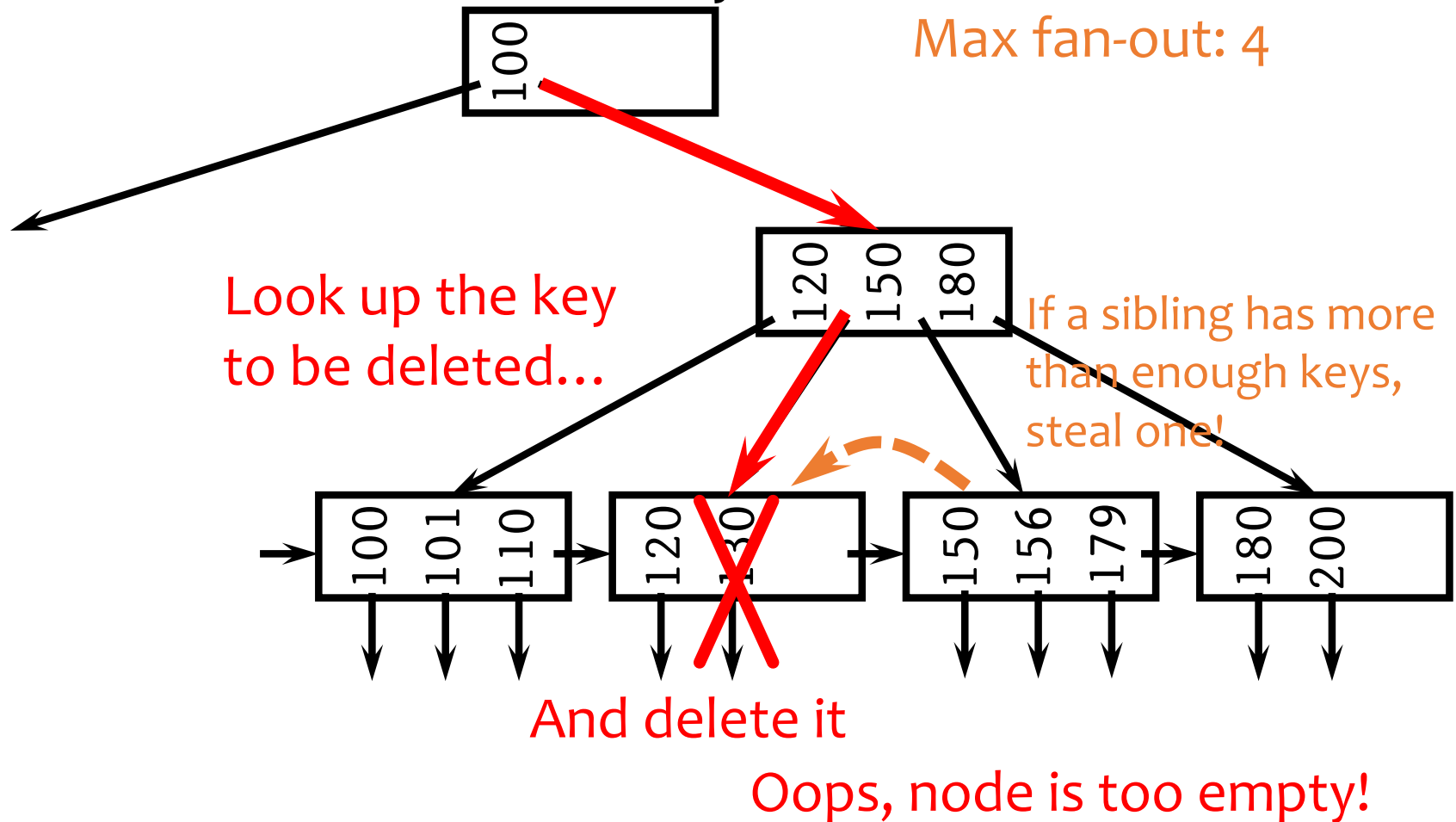

Stealing from a sibling

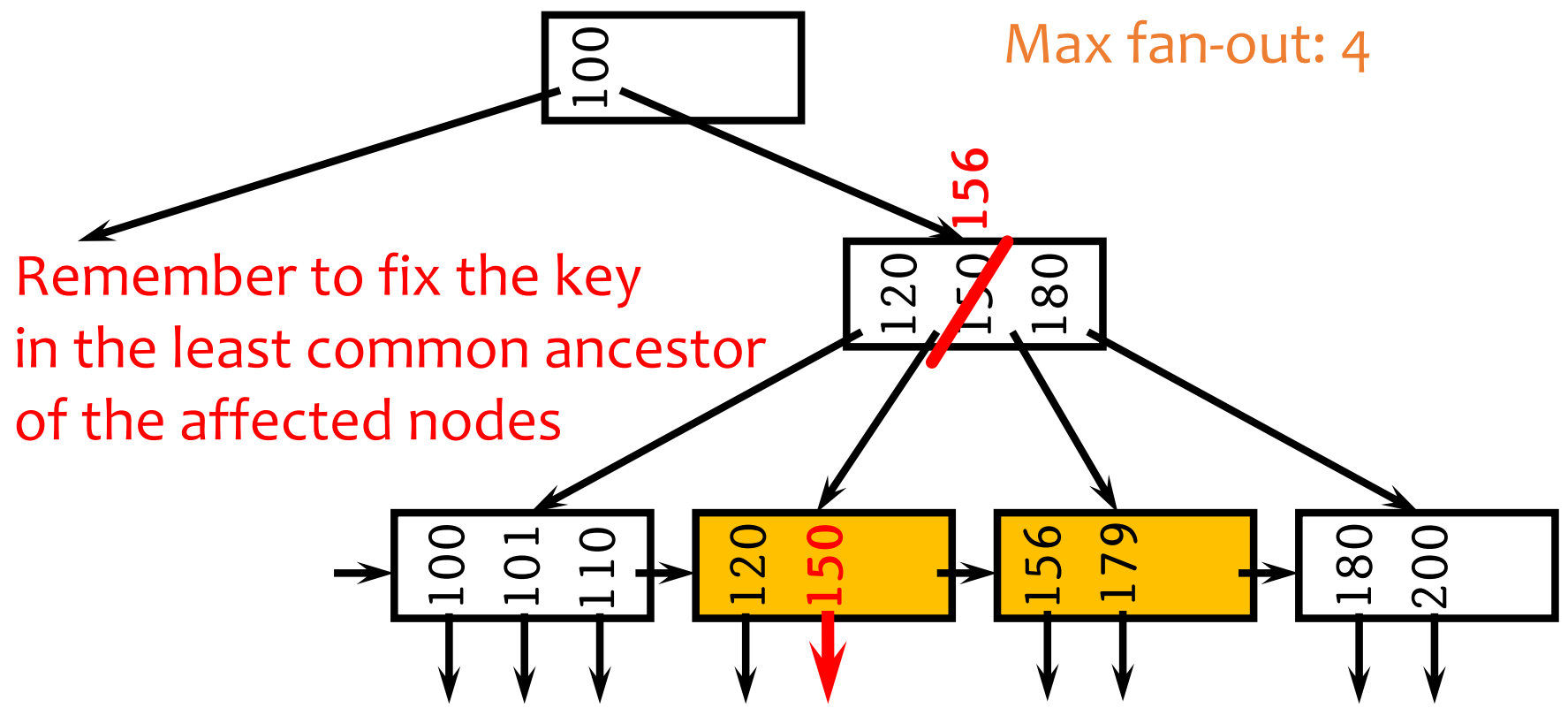

Another deletion example

- Delete a record with search key value 179

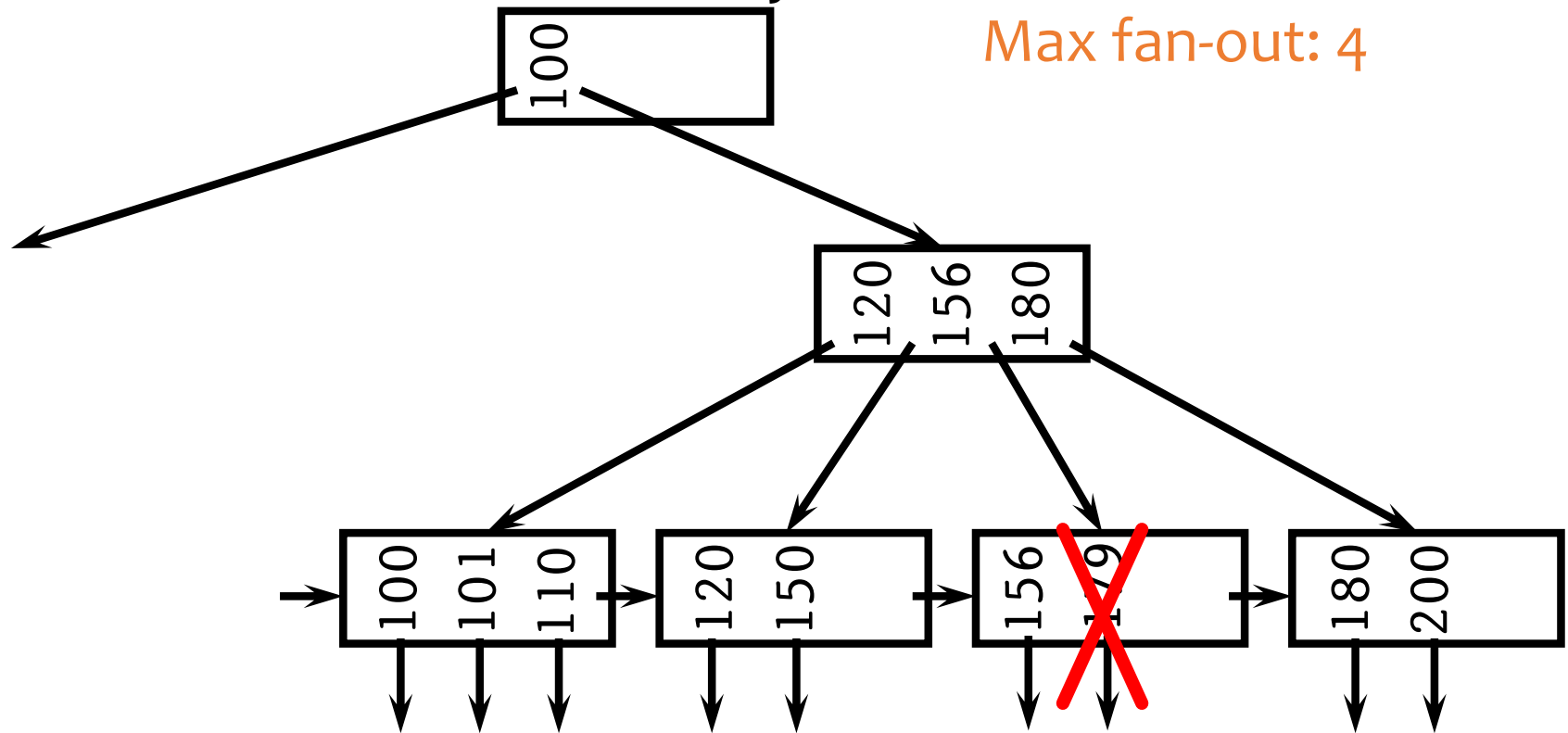

Coalescing

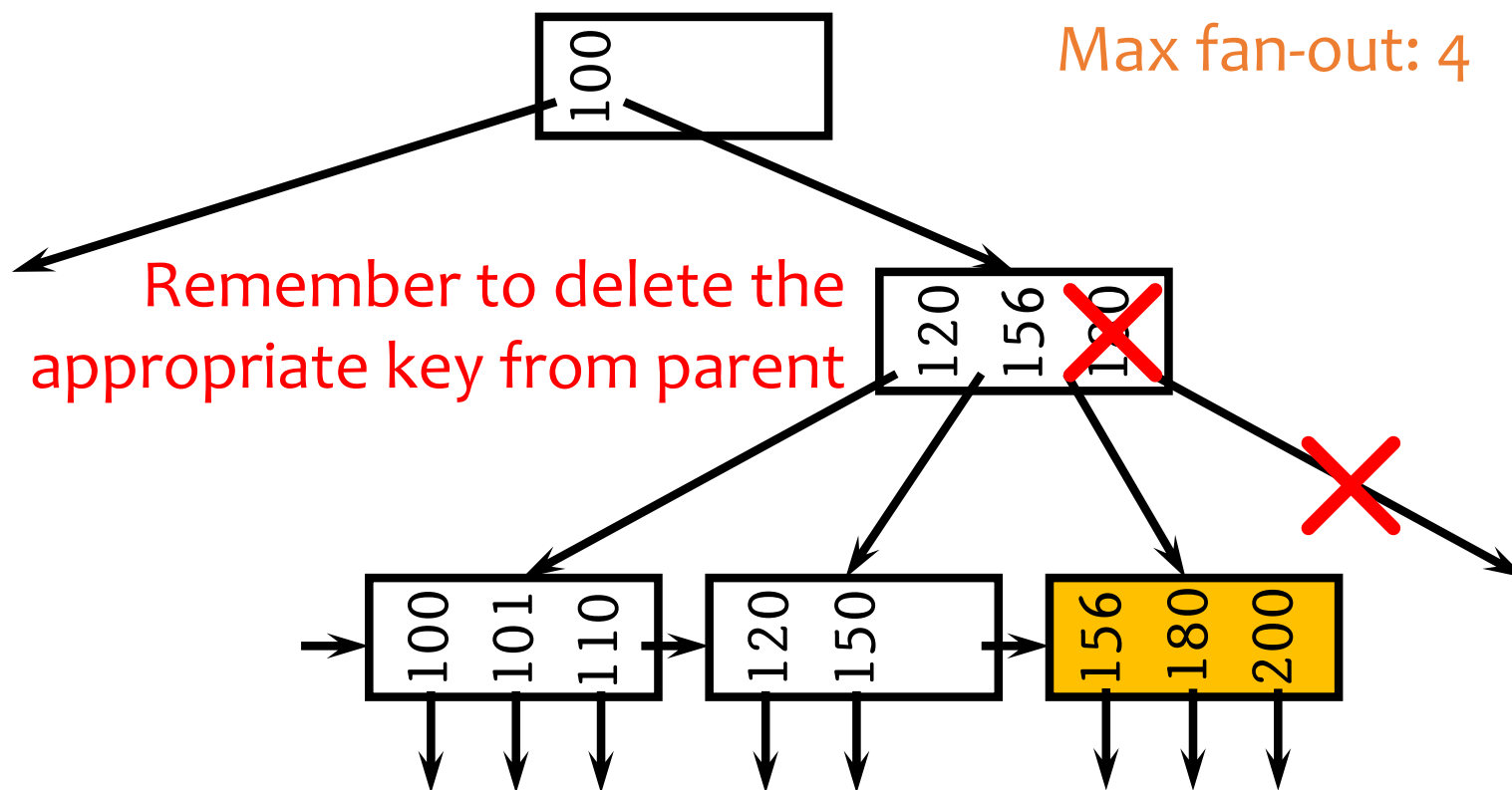

- Deletion can “propagate” all the way up to the root of the tree (not illustrated here)
 - When the root becomes empty, the tree “shrinks” by one level

Performance analysis

- How many I/O's are required for each operation?
 - h , the **height of the tree** (more or less)
 - Plus one or two to manipulate actual records
 - Plus $O(h)$ for reorganization (rare if f is large)
 - Minus one if we cache the root in memory
- How big is h ?
 - Roughly $\log_{\text{fanout}} N$, where N is the number of records
 - B⁺-tree properties guarantee that fan-out is least $f/2$ for all non-root nodes
 - Fan-out is typically large (in hundreds)—many keys and pointers can fit into one block
 - A 4-level B⁺-tree is enough for “typical” tables

B⁺-tree in practice

- Complex reorganization for deletion often is not implemented (e.g., Oracle)
 - Leave nodes less than half full and periodically reorganize
- Most commercial DBMS use B⁺-tree instead of hashing-based indexes because B⁺-tree handles range queries

The Halloween Problem

- Story from the early days of System R...

```
UPDATE Payroll  
SET salary = salary * 1.1  
WHERE salary >= 100000;
```

- There is a B⁺-tree index on *Payroll(salary)*
 - The update never stopped (why?)
- Solutions?

B⁺-tree versus ISAM

- ISAM is more **static**; B⁺-tree is more **dynamic**
- ISAM can be more compact (at least initially)
 - Fewer levels and I/O's than B⁺-tree
- Overtime, ISAM may not be balanced
 - Cannot provide guaranteed performance as B⁺-tree does

B⁺-tree versus B-tree

- B-tree: why not store records (or record pointers) in non-leaf nodes?
 - These records can be accessed with fewer I/O's
- Problems?

Beyond ISAM, B-, and B⁺-trees

- Other tree-based indexes: R-trees and variants, GiST, etc.
 - How about binary tree?



vs.



- Hashing-based indexes: extensible hashing, linear hashing, etc.
- Text indexes: inverted-list index, suffix arrays, etc.
- Other tricks: bitmap index, bit-sliced index, etc.